

Real-time digital collaboration interphases for timber structure analysis and calculation

Matias Penroz
Institut für digitale Bau- und Holzwirtschaft IdBH
Bern University of Applied Sciences
Biel/Bienne, Switzerland



Real-time digital collaboration interphases for timber structure analysis and calculation

1. Introduction

Timber buildings have been planned in a digital and industrialized fashion over the past decades, developing structured interphases for model-based communication even before Building Information Modeling (BIM) was introduced. Moreover, BIM has become the standard methodology to strengthen the digital model-based collaboration within the Architecture, Engineering and Construction (AEC) industry.

However, load-bearing structural planning for timber buildings using BIM requires iterative modelling exchanges (iteration loops) between detailed and non-detailed digital models (multi-scale models) from different disciplines, i. e. architecture and structural engineering. These iteration loops tend to overinform models, making the data analysis process within a model-based collaboration a complex task to perform, especially for industrialized timber construction where a high level of coordination in the early stages of buildings is required. Among model-based interphases, parametric modelling techniques perform well in reducing iteration loops, especially for complex multi-scale model systems. Additionally, real-time model-based interphases could be ideal for enhancing digital communication between architecture and structural engineering.

2. Real-time collaboration

Real-time collaboration is a term used for software or technologies that allow multiple users to work together on a project in real-time or simultaneously [1]. Applied to modern digital construction processes, real-time collaboration must cover at least three main aspects:

Multiple users working together (1) on the same project (2), and simultaneously (3).

To enable multi-user collaboration in construction projects, the AEC industry needed to develop a common language or structure to handle data exchange from one software to another without losing any data in the process. However, the technical aspects of simultaneously collaborating with several digital models are not yet fully developed due to each software utilize a different file format unreadable for other software interphases (Fig. 1). Furthermore, model-based communication tends to recur to non-standardized software maneuvering to overcome computational problems when exchanging or including new attributes from one model to another.

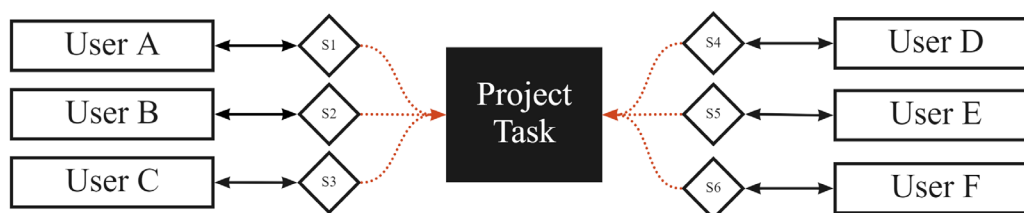

Figure 1: System expansion towards multi-user interphases. Each user is enabled to work on their Software ($S_1, S_2, S_3, \dots, S_n$).

2.1. BIM exchange protocols and IFC schema

BuildingSMART international regulates the BIM methodology and data exchange protocols, describing it as object-oriented and parametric [3]. Objects representing building elements have dynamic relations with other ones – for example, if a wall is relocated, so do the associated components. The core definition of BIM states that the parametric aspect of objects shall also cover the spatial relation between them, defining rules to define interconnected data layers. However, geometry instantiation in different software is not the same, even though objects sharing the same class will not explicitly mean sharing the

same geometry type. Real-time collaboration is one of the most significant barriers to the BIM methodology. The single model paradigm is based on a closed BIM environment where all trades operate from one centralized model containing all live project information. OpenBIM, on the contrary, is based on different trade models being continuously exchanged throughout the planning process of built assets, thus a neutral and flexible collaborative process (Fig. 2).



Figure 2: openBIM proposal for a collaborative multi-user workflow environment, different users sharing a common language, regardless of their native software.

OpenBIM collaboration is supported by the Industry Foundation Classes (IFC) standard, defined as a data structure or specification, therefore a schema rather than an exchange format [3]. IFC defines construction objects within a built asset by their attributes and parameters (BIM-Objects), thus an object-oriented specification.

2.2 Parametric methods for interoperability

Parametric design methods demonstrate a reliable manner of transferring, controlling and analyzing geometry between models based on functions and logical operations. Thus, requiring computer programming knowledge and applied mathematics to manage abstract geometrical operations between entities. One of the most common interfaces within this field is the Rhinoceros 3D/Grasshopper, based on visual design programming (VDP) to define and control geometry with the help of algorithms. These methods allow users to intuitively program and perform a series of controlled geometric actions to work out a particular design proposal.

The term algorithm refers to «a procedure or set of rules used in calculation and problem-solving» (OED Dictionary). Applied to VDP is the action of interconnecting a series of pre-defined parameters, processes, and functions to build up a specific «recipe» to solve a particular problem or design task (Fig. 3).

$$\text{Algorithm} = (\underbrace{\text{Semantic}}_{\text{IFC schema}} + \underbrace{\text{Geometry}}_{\text{Geometrical constraints Dimensional constraints}} + \underbrace{\text{Topology}}_{\text{Spatial relations}})$$

Figure 3: Proposed method to define the content and relation of objects with algorithmic design.

Architectural and structural engineering software combines such methods with native BIM object libraries to enhance interoperability and diminish user error when analyzing complex models containing significant amounts of variable and undefined entities with interdependent requirements from different disciplines. However, further development of exchange protocols to systematically manage parametric IFC entities throughout the construction planning process for load-bearing timber structures has not been addressed.

3. Model-based quality gates

The BIM methodology is based on a series of exchange phases where models are generally exchanged from one coordination phase to another specific level of development (LOD) correlating to five key stages of a project from 100 to 500 [4]. Consequently, several instances to allocate attributes of construction entities occur within one development phase, resulting in a condensed collection of data merged into heavy coordination models for each phase (Fig. 4).

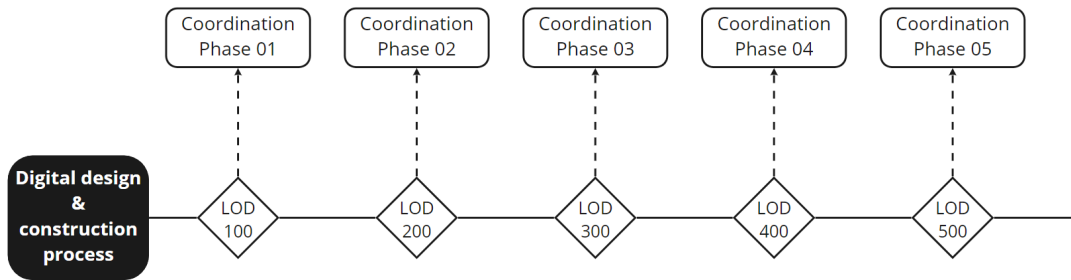

Figure 4: Linear description of the development and coordination process within a BIM workflow

Such a planning process is not compatible with timber buildings since assemblies are not planned by linear processes in which data enrichment is only validated by a specific LOD [5]. Iterative exchanges of digital models (iteration loops) must enable a flexible yet systematic construction of interconnected layers with different LOD demanding early recognition of anchoring geometry to allocate requirements (placeholders).

3.1 Data-Vessels

A suitable technique to simplify and reduce layer combinations is splitting construction components into three main layers creating a layering system [5].

The proposed methodology uses generic bounding boxes (data vessels) to transform complex layering systems into simplified geometric entities, avoiding the exchange of condensed data over phases. In addition, data vessels carry the minimum geometric and alphanumeric information to perform analysis and adjustments between phases and models. A core layer represents the load-bearing system, whereas the sublayers either a facade or an interior layer regarding the component spatial position within the built asset. After defining the scope of data vessels and the layering system, models exchange protocols need to be implemented.

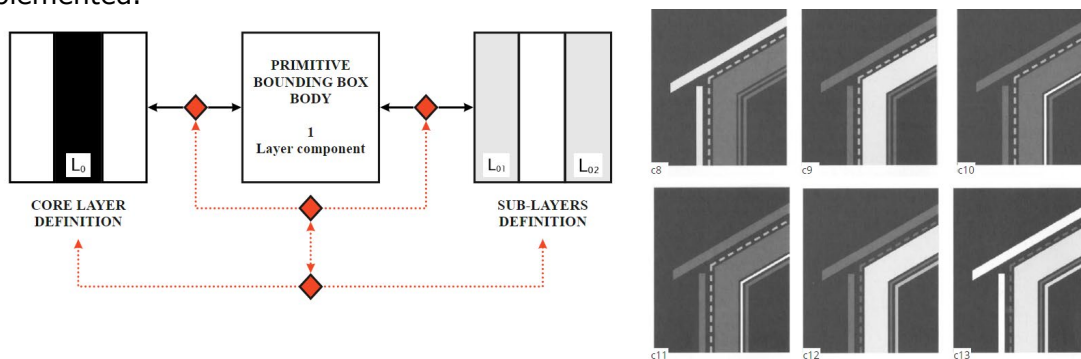

Figure 5: Schematic representation for multi-layer development of complex building components.

For such purposes, a two-steps approach will cover the modelling iteration loops and the structure of coordination models, redefining in this manner how data is created and thoroughly parametrized to accomplish project goals:

- Coordination phases must be correlated with target project milestones instead of project LOD, defining and constraining modelling purposes, requirements, and the scope of the data use, and
- Data vessels are defined by placeholders, merging multi-layer components into simplified geometry.

By this, data vessels cover the possibility that any incoming data can be created within a particular milestone regardless of their LOD and subdividing them into operative layers based on spatial position (Fig. 5).

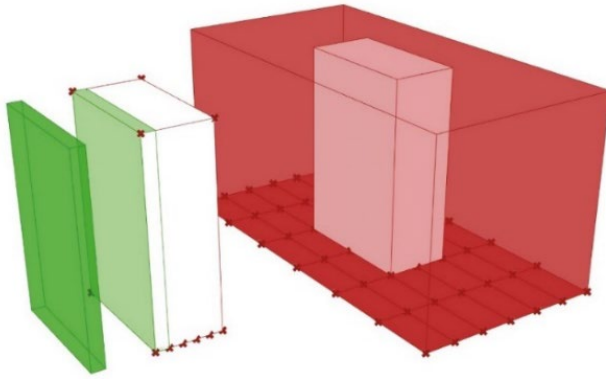

Figure 6: Data vessels in the form of simplified bounding boxes representing IFC entities when transferring data, vertical core element with a related division wall component.

For timber construction, layers represent and allocate the different requirements of disciplines involved in the planning sequence. Thus, not all data is necessarily allocated into one single layer but into sublayers which dependence can be parametrized by data vessels. The layering system represents a simplification of the possible layer combination within a data vessel, where different layer arrangements can describe timber assemblies. By this, layers are categorized according to their function and location within a building asset (Fig. 6). As a result, attributes are attached to single-layer data vessels and consequently to the sub-layers based on their functionality, defining spatial relations, and enabling data vessels to inherit requirements or attributes from parent classes (Fig. 7).

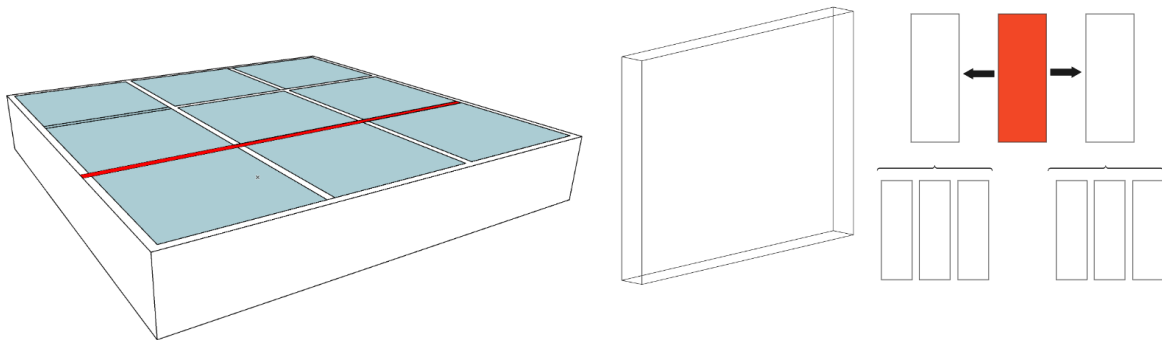

Figure 7: Volumetric process of a single IfcWall entity derived from the adjacent room configuration. Sub-layers are created from the parent entity, inheriting the requirements according to the sublayers functionality

Furthermore, if coupled with parametric design methods, designers could develop specific algorithms for each development phase and deploy model-based quality gates for coordination purposes, averting overinformed models transferring all gathered data from one phase to another. Model exchange instances within development phases are reduced, and interconnected parametrized data vessels throughout the planning process are structured (Fig. 8). The advantage of this process is that planning teams are encouraged to define early input-output constraints for data vessels based on project milestones instead of non-regulated LOD, shifting the design process from a push to pull methodology [6]. The creation of data is only to fulfil the requirements of a specific milestone, and instead of larger models for multiple purposes, simplified models for target milestones are created.

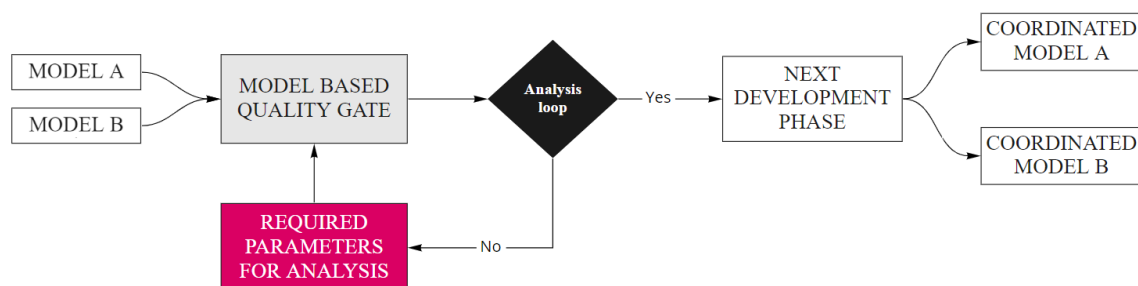

Figure 8: Generic process definition for model-based quality gates implementation.

For interoperability purposes, project milestones will derive the model-based quality gates with correspondingly parametrized barriers to retain data and test models against each other to examine whether the predefined data-vessels requirements fulfil the project milestone or not (Fig. 9).

The system's definition is in this regard based on three main components:

- Construction classes correlated with an IFC entity represented by a spatial bounding-box structured into data vessels,
- Parametrized data vessels describing the entity's attributes or state and
- Parametrized quality gates defined by project milestones and input-output requirements criteria, extracted by the milestone definition.

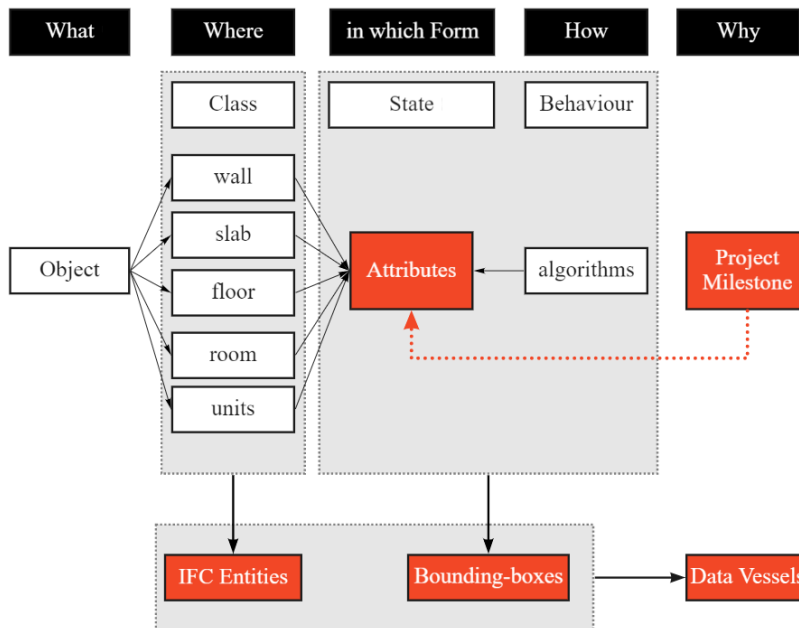

Figure 9: Extension of object classes categorization diagram includes project milestones and their influences on defining boundary conditions for data-vessels.

After structuring the content and instantiation of data vessels, topological relationships between them shall indicate how individual entities spatially relate to each other [7]. These spatial relations are of utmost relevance for designers since attributes can be inherited from one entity to another or be a calculated result based on spatial relations between them, even across non-corresponding classes, i.e. room attributes to wall or slab elements (Fig. 10).

Furthermore, superordinate spatial dependencies among entities allow a more precise definition of spaces, mainly if changes in earlier phases must be executed when specific project requirements do not comply with the intended design.

Requirements

$$\text{Room.A} + \text{Room.B} = \text{ConstructionComponent}$$

LayerConstruction

$$\text{ConstructionComponent} = 1\text{LayerConstructionComponent}$$

$$1\text{LayerConstructionComponent} = L1+L2+L3+... Ln$$

Figure 10: Spatial construction and allocation of the requirements for individual construction components

Combining topology with semantic models creates a systematic and robust manner to preserve intrinsic spatial conditions over project milestones. Without establishing topological relations between entities, designers cannot thoroughly define spaces in the sense of spatial continuity from one entity to another (Fig. 11).

Thus, models from early development phases could not be tested or analyzed against later ones due to non-existing spatial relationships. By this, zones and rooms may define spatial reference elements such as points, edges and surfaces, where walls, columns, or beams can be instantiated in further reference models, defining relationships between classes over primitive geometrical elements. Hence, closing the loop between spatially interconnected entities coexisting at the same location but in different development phases.

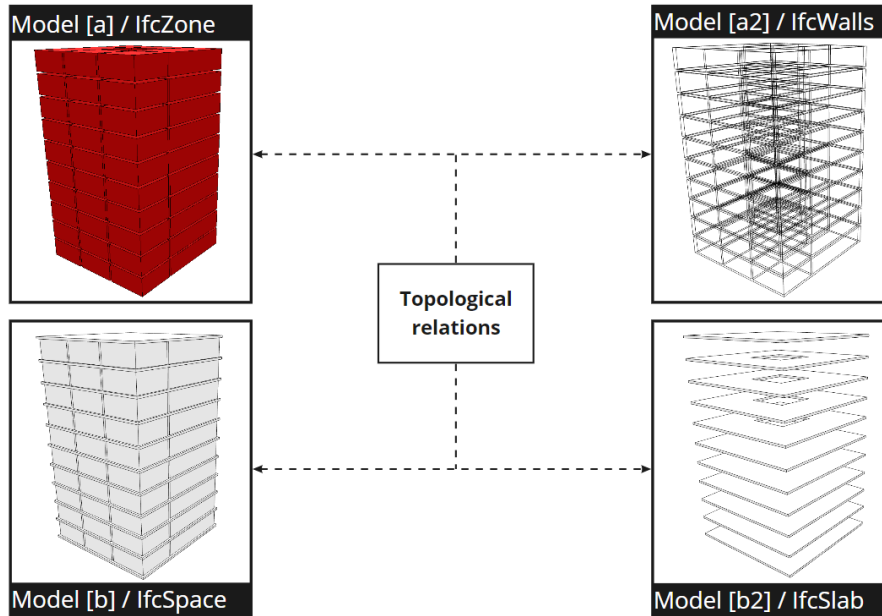

Figure 11: Topology and semantic relations

3.2 Interphase implementation

Project objectives and requirements define how BIM models interact throughout the planning process by defining roles and exchange phases. Typically, such data is stored within a BIM execution plan (BEP), transferred to the information delivery manual (IDM) and organized into use cases which will structure data into model view definitions (MVD), finally utilizing the IFC specification schema to relate entities into semantic construction objects [8].

From these methods, a sequence of exchange phases and project coordination gates are defined and agreed upon from the very beginning (Fig. 8). As previously proposed, defining project milestones contribute to the early identification of valuable criteria for the model-based quality gates describing the minimum input-output requirements for real-time interphases between disciplines. The proposed setup methodology expands the linear delivery process from the BIM methodology towards structured iteration loops supporting variable LOD data consolidation towards real-time collaboration interphases.

To accurately switch from a push to a pull process, the triggering of any activity related to data creation is covered by the predefined milestones. Therefore, buffering of data waiting to be analyzed is avoided by acting only over specific tasks and the exchange of models is replaced by real-time collaboration interphases to coordinate data towards the target milestone.

The generic process architecture (Fig. 11) represents the proposed pull data stream to define and create models systematically. Starting from a specified milestone, defining the requirements to construct the model-based quality gates will determine the parameters over which different disciplines can build models.

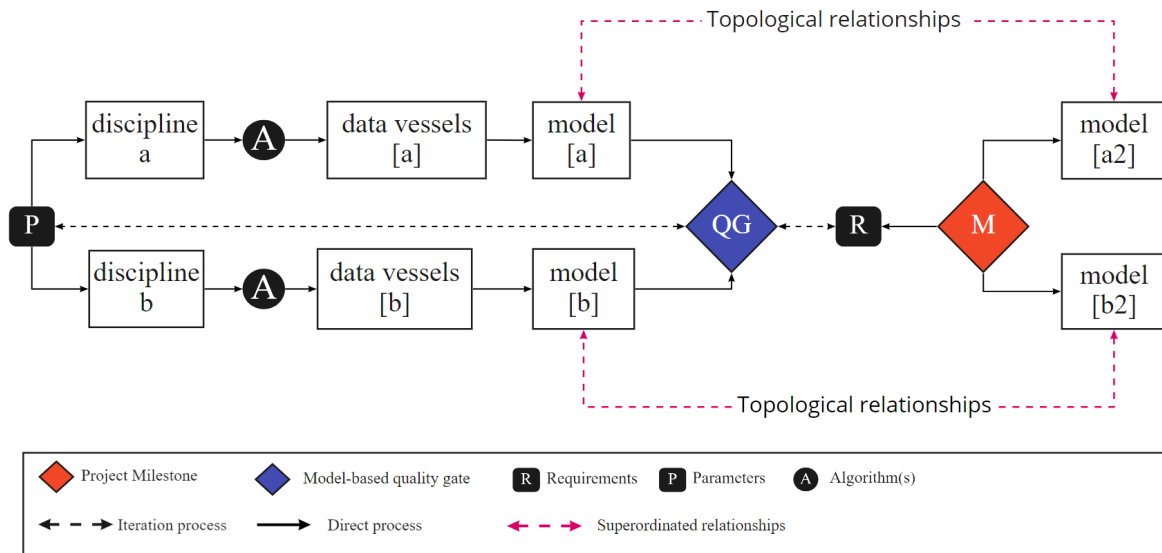

Figure 11: Detailed process architecture of pull planning methods to validate the structure and content of different discipline models and their resulting data vessels.

Even though project milestones define the alignment of modelling purposes, spatial relations within models act as a superordinated definition to link data vessels between non-corresponding classes without losing the primitive parent topology. This means that by preserving a clear description of models topology, traceability of changes or inheriting attributes from one class to another can be assessed by user-defined algorithms.

It is to be also tested that models from earlier phases can influence models in later ones because the system is proven to work with minor buffering of data.

Following the pull planning principle:

→ Fewer exchange phases → fewer data to be created → fewer communicational issues.

For load-bearing structures in timber buildings, the following milestones are proposed to manage the iterative loops to develop layering systems systematically. Each milestone is controlled by a model-based quality gate and described by a use case (Table 1).

Table 1: Milestones system for the layer development and coordination in timber structures

	Milestone	Model-based quality gate	Use Case
M1	Global Structural Analysis	Core and shell model analysis	Reference System Model
M2	Prefabrication level Analysis (scope/def)	Single-layer range model analysis	Breakthrough Coordination model
M3	Construction System Analysis	Three-layer range model analysis	Raw construction model

3.3 Reference models

To practically test and illustrate the systematic development of model-based quality gates, a generic case study building is selected and defined by following attributes (Fig. 12):

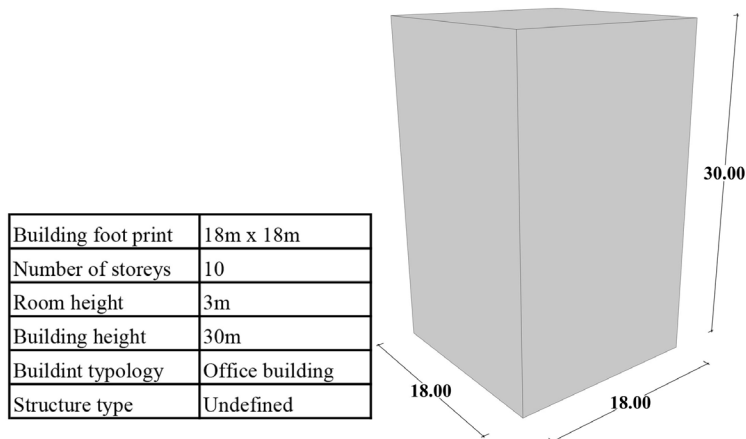

Figure 12: Definition of the case study building to test the proposed methodologies. Boundary conditions are defined according to the left-sided table and right-sided figure

Secondly, the project milestone defines the boundary conditions of how disciplines shall interact (Fig. 13). For these research purposes, the test setup involves two disciplines; Structural Engineering and Architecture, where the milestone requirements restrict both domains, thus the scope of data generation is reduced by only «modelling» what is requested by the model-based quality gate definition.

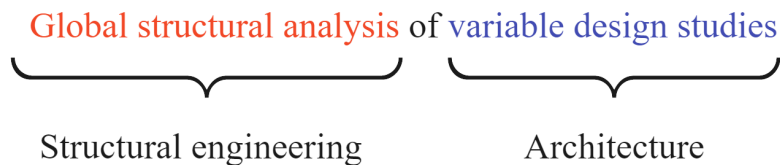

Figure 13: Definition of the project milestone and the identification of the two interacting disciplines for the real-time collaboration instance.

With this, two relevant steps are accomplished before sorting the individual parameters for the model-based quality gate:

- The project milestone definition covers two different disciplines: structural engineering and architecture
- Input-output requirements can be tested on a model-based quality gate, and simultaneously the necessary parameters to define and structure the data vessels content are defined.

On the one hand, data vessels represent an idealized version of the geometrical properties of a built asset. On the other hand, IFC entities correspond to the semantic description of the physical material version of components such as walls, slabs or beams. To systematically reach the proposed milestone, interconnected models are parametrically constructed and linked within each other. The proposed models are defined as follow:

1. Raw geometry model
2. Mass model
3. Room model
4. Core and shell model
5. Analytical model
6. Single-layer components model

These reference models are developed by defining raw geometry in Rhino/Grasshopper, including semantic information from Archicad and performing the structural analysis to estimate the core layer dimension in RFEM by iterative loops (Fig. 14).

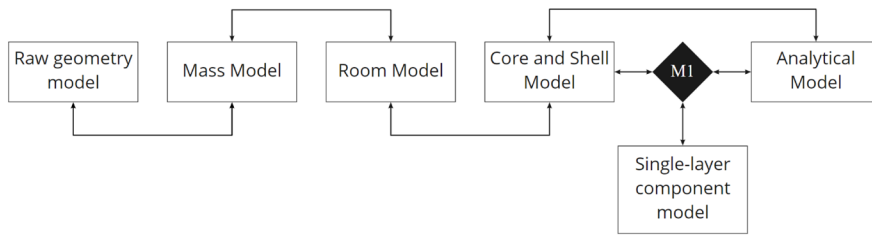

Figure 14: Process Architecture for the interaction between models in an iterative digital workflow environment

4. Model-based quality gates

Additionally, the spatial relations within all reference models algorithms are defined using the Topologic toolkit for Grasshopper developed by TopologicApp. The latter allows controlled user-defined modifications in real-time when facing the model-based quality gates without losing spatial continuity between coexisting entities. These techniques allow for recursive analysis by using abstract topological components such as faces, edges or vertices, to act as «supports» when defining BIM Queries for IFC entities. Topological queries are used to evaluate further design steps, i.e., searching and listing all adjacent data-vessels of a particular one or identifying all data-vessels with shared edges [9]. Furthermore, by utilizing VDP, the interoperability between models is executed by parametrized interphases. Different data types may be allocated among models without losing the continuity from one model to another while defining the needed reference elements. (Fig. 15).

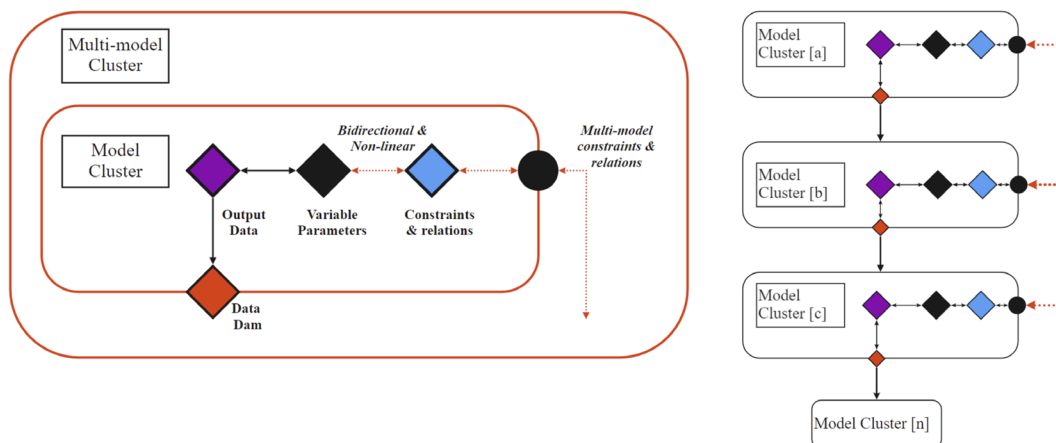

Figure 15: System definition for interconnected parametric models. Interoperability setup between clusters. Black dots as an open gate towards requirements based on constraints and relations between data.

4.1 Modelling iteration loops

The parametric script is ruled by a set of separated definitions linked to each other (model cluster) containing four main aspects:

- target-specific parameter sets,
- variable parameters,
- output data and a final
- data dam as final instance of the interphase to «retain» data before transferring it to the following reference model.

Each reference model is intended to exhibit a common data structure to allocate variable data vessel typologies and several model clusters comprise a multi-model cluster system. The proposed process architecture, defining in this manner the algorithmic interphase to link data among them (Fig. 16).

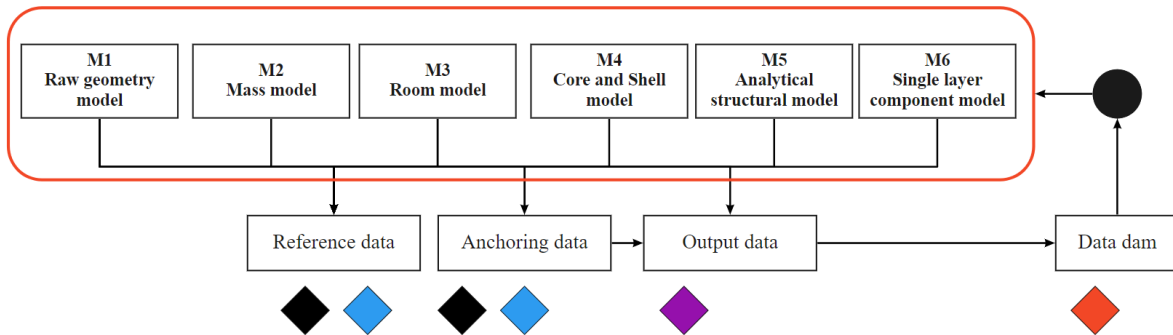

Figure 16: Process architecture for the multi-model cluster interphases

The multi-model cluster reduced the typologies of generated data by simplifying reference geometry throughout all models. In addition, topological relations contributed to managing overlapping geometry by enabling different geometry objects to share primitive geometry without duplicating them into the model (Fig. 17).

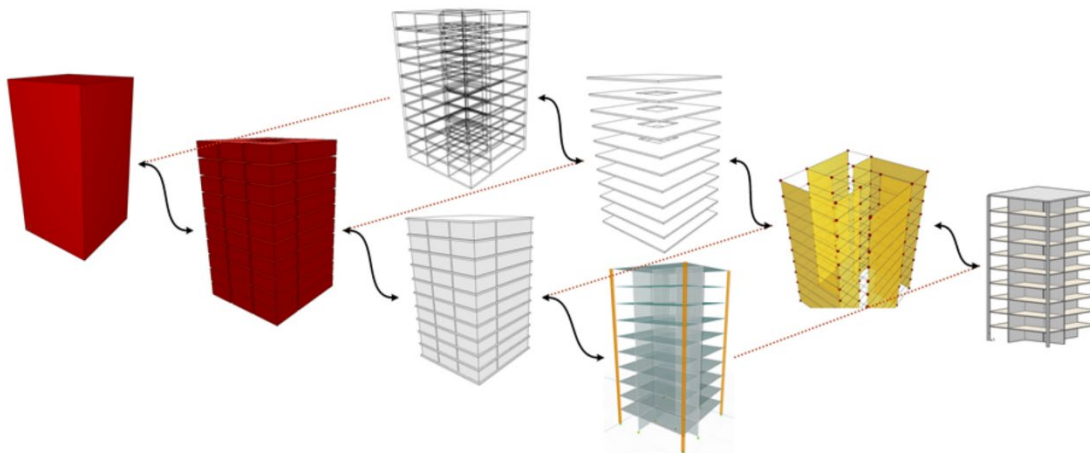

Figure 17: Summary of reference models acting as a conglomerate in an interconnected cascade effect.

However, data resulting from iterative development loops of multi-layer assemblies can neither be related nor indexed due to the lack of interconnected topological multi-scale models on a conceptual level. The proposed algorithmic interphases are programmed to ensure multi-scale operative interphases over planning phases by linking reference models based on topology, therefore reducing data creation. Moreover, by defining topological models, anchoring elements for further new spatial relations ensures that iteration loops automatically update the complete system interphase. In addition, model-based quality gates create, control and specify the layering system of topologically defined data vessels. In this regard, not only the coexistence and linkage of different entities can occur at the same location, but also the possibility of different LOD simultaneously occurring within entities can also be possible (Fig. 18).

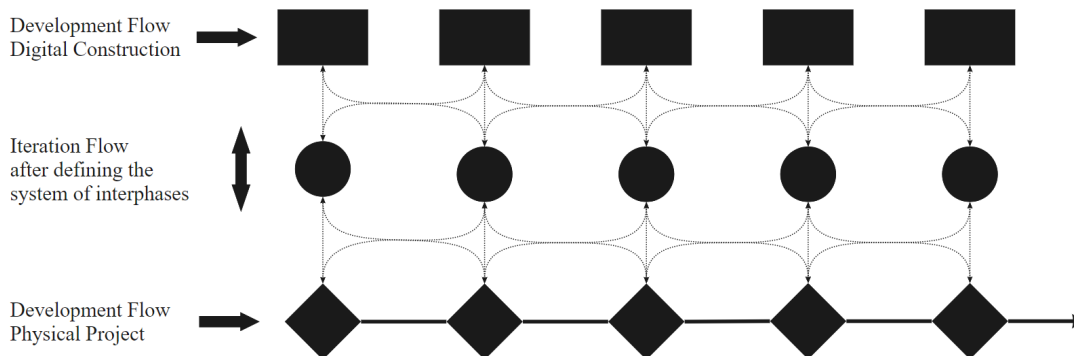

Figure 18: Iteration flow with incorporated algorithmic interphases

Planning aspects from industrialized timber construction demonstrate that modelling iteration loops benefit from defined and undefined categories for instantiating interconnected layering systems. For instance, a timber frame wall belonging to a core layer may not need to contain all individual studs to coordinate connection details between structural engineering and architecture but rather be represented by single-layer data vessels with anchoring elements. As an example, a node with all corresponding sublayers and the corresponding adjacent single-layer data vessels (Fig. 19).

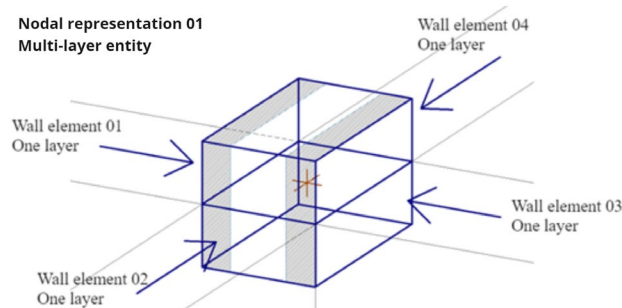

Figure 19: Graphic representation for multi-scale modelled objects; Four wall types represented by single layer entities and a structural joint represented by a multi-layer entity with the corresponding anchoring reference node.

4.2 Influences of DfMA in timber structures

Design for manufacturing and assembly has shown to be an effective planning methodology in the early phases of timber structures, mainly for two critical aspects:

- Offsite prefabrication of components requires an early estimation of needed raw material for manufacturing purposes.
- Timber structures commonly comprise complex assemblies with multi-layer systems distributed in various construction systems for vertical and horizontal load distribution.

Production know-how can be pulled into early design stages, improving assembly sequences, a better quality of final components, and project-specific detail catalogues for parametric joints can be thoroughly defined. In this regard, DfMA aspects can be adapted towards design for prefabricated timber construction (DfPTC) [10] by not just focusing on assembly and manufacturing aspects but also on the layer-oriented development of timber construction processes.

4.3 Layer development in timber construction

The introduced layering system method to isolate load-bearing from the non-load bearing layers determined that interphases to develop the core-layer match well with the model-based quality gates and real-time collaboration instances by showing models without any geometrical errors between the used software among analysis loops (Fig. 20)

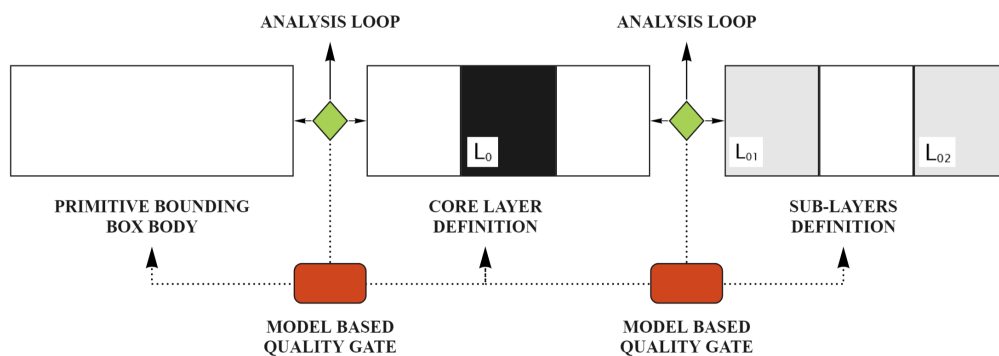

Figure 201: Layer-oriented development process coupled with multi-scale model-based quality gates.

Before implementing the layering system for the model-based quality gates, non-regulated relations between complex entities comprised unsorted data from different IFC entities. Thus, sublayer categorization cannot be correctly allocated into target data vessels due to the non-existing filtering parameter sets (Fig. 21)

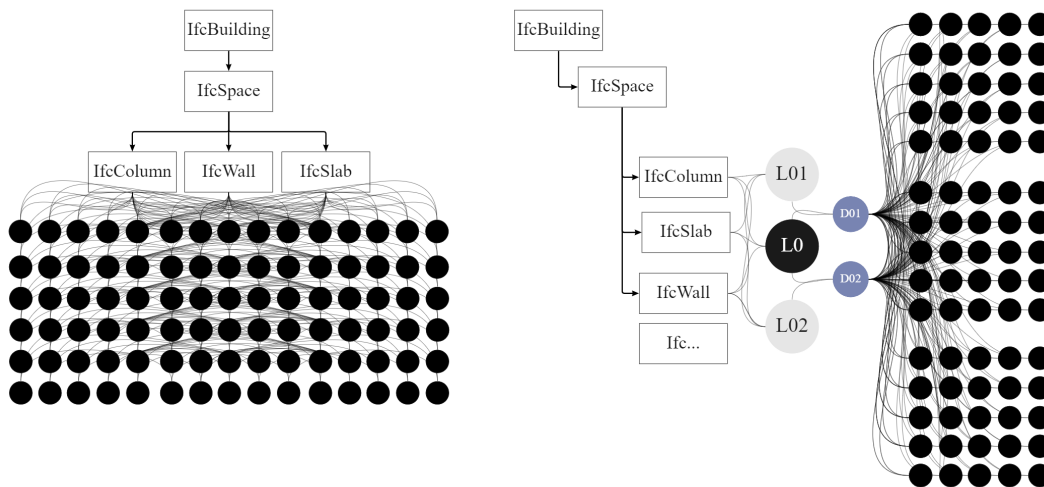

Figure 21: Abstract visualization of a non-regulated (left) and regulated (right) system for complex layering systems and varying layer combinations between non-corresponding IFC entities.

According to multi-scale models from the digital simulations (reference models 2,3,4,5, and 6), implementing up to three-layers data vessels resulted in topologically related non-corresponding classes from the IFC schema (Fig. 21).

Moreover, for the core load-bearing layer, the obtained results are:

- Simplified models with fewer data vessels
- Reduced amount of IFC entities to transmit semantic information
- Linked data between all reference models

5. Conclusions

The real-time collaboration interphases were demonstrated to simplify the model-based collaboration for planning load-bearing timber structures, averting the exchange of reference models and generating accurate geometry and semantic information of the evaluated construction components. With the systematic implementation of the layering system, a reduced amount of reference axis systems are needed to develop further subsequent layers in complex timber assemblies.

With an accurate development of multi-scale modelling techniques and defining spatially related multi-layer components, the effects of varying requirements for systems, components and assemblies can be assessed without geometric and alphanumeric information loss throughout all the planning phases of a built asset.

However, managing model-based quality gates by parametric modelling techniques towards real-time interphases cannot be organized with current BIM methodologies or data management standards. The IFC schema does not support a flexible development of spaces before construction components, leading to unrelated systems from the very beginning.

6. Acknowledgement

The author acknowledge the contribution of the BIMwood research project team.

7. References

- [1] Techopedia, (2008). Retrieved from Techopedia.com: real-time-collaboration
- [2] Jinfeng Lou, W. L. (2020). A review of BIM data exchange method in BIM collaboration.
- [3] Baldwin, M. (2019). The BIM Manager – A practical Guide for BIM Project Management.
- [4] Hausknecht, K. (2016). BIM-Kompodium – Building Information Modeling als neue Planungsmethode: IRB Verlag.
- [5] Kolb, J. (2008). Systems in Timber Engineering. Basel, Boston, Berlin: Birkhäuser.
- [6] Nicholas, J. (2011). Lean production for competitive advantage. New York: Productivity Press Taylor & Francis Group.
- [7] G. Arun Francis, S. M. (2018). A perspective approach to set topological definitions. International of Pure and Applied Mathematics, 118(20), 485-490.
- [8] A. Borrmann, A. K. (2015). Building Information Modeling – Technologische Grundlagen und industrielle Praxis. Wiesbaden: Springer.
- [9] R. Aish, A. P. (2012). Spatial Information Modeling of Buildings Using Non-Manifold Topology with ASM and Design Script. Advances in Architectural Geometry, 25-36.
- [10] BIMwood (2022); <https://sites.hslu.ch/architektur/bimwood/>